

# **HTM SL Ultrasonic level meter**

## **OPERATION MANUAL**

---

**HTM**

INSTRUMENTS SDN BHD

## NOTICE

---

This manual is designed to promote personal and system safety and to optimize product performance. It should be read carefully before installing, using, or maintaining the indicator. If the product is used in a manner not specified by HTM INSTRUMENTS SDN BHD, the protection provided by the product may be impaired. If a problem occurs that is not resolved in the manual, refer to your nearest authorized supplier or the details listed below for service and support.

---

**HTM Instruments Sdn Bhd**  
29, Jalan SG10/4, Taman Seri Gombak  
68100 Batu Caves, Selangor, Malaysia  
Tel: 603-61895009, Fax: 603-61891639  
email: htmsb@hydrotrent.com

## **Table of contents**

### **HTM SL Ultrasonic level meter**

- 1.0 Product overview
- 2.0 Display & Calibrations
- 3.0 Operations
  - 3.1 Range full scale
  - 3.2 Range zero
  - 3.3 Zero offset
  - 3.4 4mA output current
  - 3.5 20mA output current
  - 3.6 Gain
- 4.0 Calibration procedures
  - 4.1 Instrument calibration
    - 4.1.1 Setting to work
    - 4.1.2 Changing instrument range
    - 4.1.3 Calibration of 4mA output current
    - 4.1.4 Calibration of 20mA output current
  - 4.2 Sensor module calibration
    - 4.2.1 Calibration for level meter
    - 4.2.2 Calibration for distance meter
- 5.0 Installations
- 6.0 Specifications

## **1.0 Product overview**

HTM SL Ultrasonic level meters are the state of art level sensors that utilizing ultrasonic wave to measure water level in storage tank. It can also be used to measure the distance between the sensor and any flat surface that reflects sonic waves. The measured parameter is displayed on a 3 ½ digit LCD display for direct readout and also converted into 4-20mA current signal for remote indication & processing.

## **2.0 Display & Calibrations**

The front panel of HTM SL Ultrasonic level meter consists of a 3 ½ digit 7 segment LCD display for the display of instantaneous water level. The level displayed can be adjusted to any unit such as meter, cm, feet, inches etc.

Calibration of HTM SL Ultrasonic level meter is through adjustment of potentiometer mounted inside the converter. Parameters which can be adjusted include the following:

- Range full scale
- Range zero
- Zero offset
- 4mA output current
- 20mA output current
- Sensitivity

## **3.0 Operations**

### **3.1 Range full scale**

Range full scale is printed as `RANGE F.S.' in the converter unit. This is for the adjustment of full scale range of the instrument. i.e when the tank is full.

### **3.2 Range zero**

Range zero scale is printed as `RANGE ZERO' in the converter unit. This is for the adjustment of range zero of the instrument. i.e when the tank is empty

### **3.3 Zero offset**

Zero offset is printed as `ZERO OFFSET` in the converter unit. This is for the correction of level offset due to sensor position. i.e to offset the reading to match the actual water level.

### **3.4 4mA output current**

4mA output current adjustment is printed as `4mA` in the converter unit. This is for the adjustment of 4mA output. i.e to set 4mA current output for zero water level.

### **3.5 20mA output current**

20mA output current adjustment is printed as `20mA` in the converter unit. This is for the adjustment of 20mA output. i.e to set 20mA current output for full scale water level.

### **3.6 Gain**

Gain adjustment is for setting sensitivity of measurement and also the stability of reading in the presence of disturbances.

## **4.0 Calibration procedures**

Two types of calibration procedures can be carried out, i.e Instrument calibration & Sensor module calibration.

### **4.1 Instrument calibration**

Instrument calibration is carried out during start-up after installation of SL level meter. It involves simple site calibration which utilizes factory calibrated data to re-calibrate the instruments. This includes setting instrument to work, changing of instrument range, calibration of 4mA & 20mA output current.

#### **4.1.1 Setting to work**

Install the SL converter and sensor according to instruction in section 5. Make sure the echo LED light is lighted up & Calibration link is set at

the `Run` position. Turn the `Zero offset` potentiometer to obtain a reading on the LCD display to match the actual water level.

#### **4.1.2 Changing instrument range**

To change the instrument range, firstly put the calibration link at `Set zero` position and adjust the `Range zero` potentiometer to obtain zero reading on the LCD display. Then put the Calibration link in the `Set F.S.` position and adjust the `Range F.S.` potentiometer to obtain the required full scale reading on the LCD display. If the range to be set is less than 4 meter, short the link marked `Low range` with another link provided in the converter.

#### **4.1.3 Calibration of 4mA output current**

Connect a multimeter or mA meter to the output of SL level meter. Put the calibration link at the `Set zero` position. Adjust the `4mA` potentiometer until the output is exactly 4.00mA.

#### **4.1.4 Calibration of 20mA output current**

Connect a multimeter or mA meter to the output of SL level meter. Put the calibration link at the `Set F.S.` position. Adjust the `20mA` potentiometer until the output is exactly 20.00mA.

### **4.2 Sensor module calibration**

Sensor module calibration is carried out in cases where SL level meter is to be converted into a distance measuring instrument or there is problem with the stability of the instrument readings.

#### **4.2.1 Calibration for level meter**

To carry out sensor module calibration to function as a level meter, follow the steps below:

- 1) Connect the ultrasonic sensor to the converter and switch on the power supply to the instrument.
- 2) Set the Calibration link to `Run` position

- 3) Direct the sensor to a solid flat surface such as a building wall about 11.5 meter away. (Maximum distance should not exceed 12 meter)
- 4) Depress and hold the `MIN` push button on the sensor module, wait for the echo LED to stop flashing and the transducer generates a `chirp` sound before releasing.
- 5) Move the sensor to about 0.5 meter away from the flat surface. (Minimum distance should not be less than 300mm)
- 6) Depress and hold the `MAX` push button on the sensor module, and wait for the echo LED to stop flashing and the transducer generates a `chirp` sound before releasing.
- 7) Move the sensor to exactly 11.0 meter away from the flat surface. Adjust the `Zero offset` potentiometer until the LCD display shows exactly 0.00 meter
- 8) Move the sensor to exactly 1.0 meter away from the flat surface. Adjust the `LCD SPAN` potentiometer on the display module until the LCD display shows exactly 10.00 meter
- 9) Repeat the above process until exact reading of 0 & 10 meter readings are obtained against the respective flat surface distances.
- 10) In the event of too much interference or signal strength too low from the flat surface, adjust the `GAIN` potentiometer until a good result can be obtained. (see note 1 below)
- 11) Follow the procedure for Instrument calibration to calibrate the zero and full scale output current of the instrument.
- 12) Sensor module calibration is complete

#### **4.2.2 Calibration for distance meter**

To carry out sensor module calibration to function as a distance meter, follow the steps below:

- 1) Connect the ultrasonic sensor to the converter and switch on the power supply to the instrument.
- 2) Set the Calibration link to `Run` position
- 3) Direct the sensor to a flat surface such as a building wall about 0.5 meter away. (Minimum distance should not be less than 300mm)

- 4) Depress and hold the `MIN' push button on the sensor module, wait for the echo LED to stop flashing and the transducer generates a `chirp' sound before releasing.
- 5) Move the sensor to about 11.5 meter away from the flat surface. (Maximum distance should not exceed 12 meter)
- 6) Depress and hold the `MAX' push button on the sensor module, and wait for the echo LED to stop flashing and the transducer generates a `chirp' sound before releasing.
- 7) Move the sensor to exactly 1.0 meter away from the flat surface. Adjust the `Zero offset' potentiometer until the LCD display shows exactly 0.00 meter
- 8) Move the sensor to exactly 11.0 meter away from the flat surface. Adjust the `LCD SPAN' potentiometer on the display module until the LCD display shows exactly 10.00 meter
- 9) Repeat the above process until exact reading of 0 & 10 meter readings are obtained against the respective flat surface distances.
- 10) In the event of too much interference or signal strength too low from the flat surface, adjust the `GAIN' potentiometer until a good result can be obtained. (see note 1 below)
- 11) Follow the procedure for Instrument calibration to calibrate the zero and full scale output current of the instrument.
- 12) Sensor module calibration is complete

**Note 1:** The `GAIN' potentiometer is preset at factory for optimum performance. To re-calibrate the potentiometer, place the sensor at the maximum desired detection distance (11.5M). First, rotate the `GAIN' potentiometer fully counter-clockwise (CCW). Then, slowly rotate the same potentiometer clockwise (CW) until detection occurs. Rotate the potentiometer CW for an additional 1/16 turn.

## 5.0 Installations

HTM SL ultrasonic level sensor must be mounted on a rigid structure and vertically and target to water surface which is reasonably calm. Excessive turbulent water surfaces such as near to water fountain and inlet pipe can cause unstable level readings. Care must be taken during installation so that the sensor is not subjected to condensation of water vapour which can cause error in readings.

The SL converter is housed in an IP65 enclosure and must be mounted indoor or inside a reasonably ventilated weatherproof enclosure. Excessive heat on the converter in outdoor enclosure without ventilation can cause permanent damage to the instrument.

In order for the instrument to work properly, the sensor shall be properly aligned to obtain a good echo from the water surface or measured surface. Make sure the echo LED light is lighted up for this purpose. The echo LED will not light up if no echo is received by the sensor. Re-calibrate the 'GAIN' potentiometer if necessary.

Typical installation of sensor

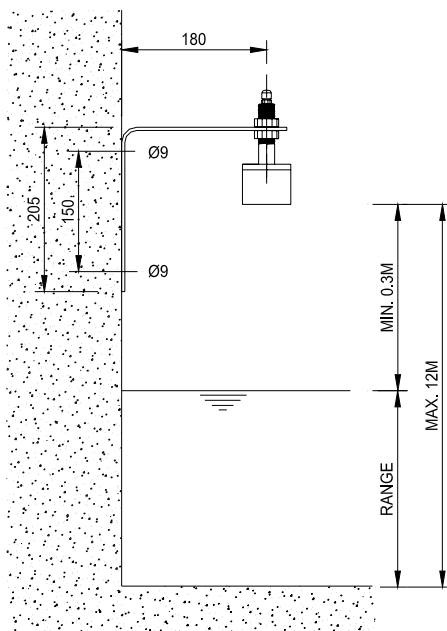

Wiring diagram

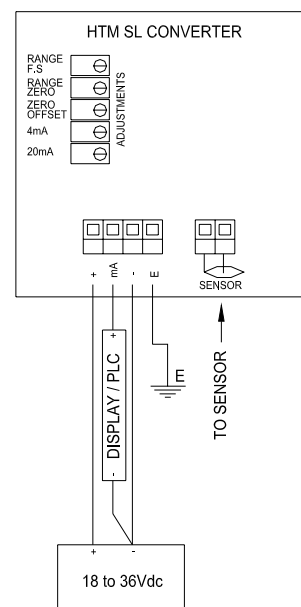

## 6.0 Specifications

Power supply: 18 to 36Vdc  
Power consumption : 2W  
Display : 12.7mm ht 3 ½ digit LCD  
Accuracy : +/- 0.1% FS  
Linearity & Repeatability : +/-0.25% FS  
Resolution : 10mm  
Long term stability : +/-0.25% FS  
Transient protection : 10kV, 10kA@8/20µS  
Calibrated ranges : 4M, 10Mwg std  
Range turn down ratio : 0.4:1.0  
Measurable range : 0.3 to 12M  
Frequency : 50kHz  
Beam pattern : 15° nominal  
Temperature : -20 to + 80°C  
Temperature compensation : Built in  
Dimensions :  
    Converter : 120 X 120 X 90 (mm)  
    Sensor : 60dia. X 146mm  
Wiring connection : 3 wires  
Output : 4-20mA, max 600 Ohms@24Vdc  
Materials of construction :  
    Converter : ABS  
    Sensor housing : UPVC  
    Sensor surface : 304 SS  
    Cable : PVC  
Degree of protection :  
    Converter : IP65  
    Sensor : IP67  
Cable type : RG62  
Diameter of cable : 6mm  
Cable gland : 2 X M16 IP68 Nylon glands  
Cable length : 5M std, optional up to 50M  
Std accessories : Sensor mounting L bracket  
Weight : Converter : 440g  
    Sensor : 210g  
    Cable : 40g/M  
    L bracket : 250g  
    Shipping : 1.1kg